

Installation Dimension

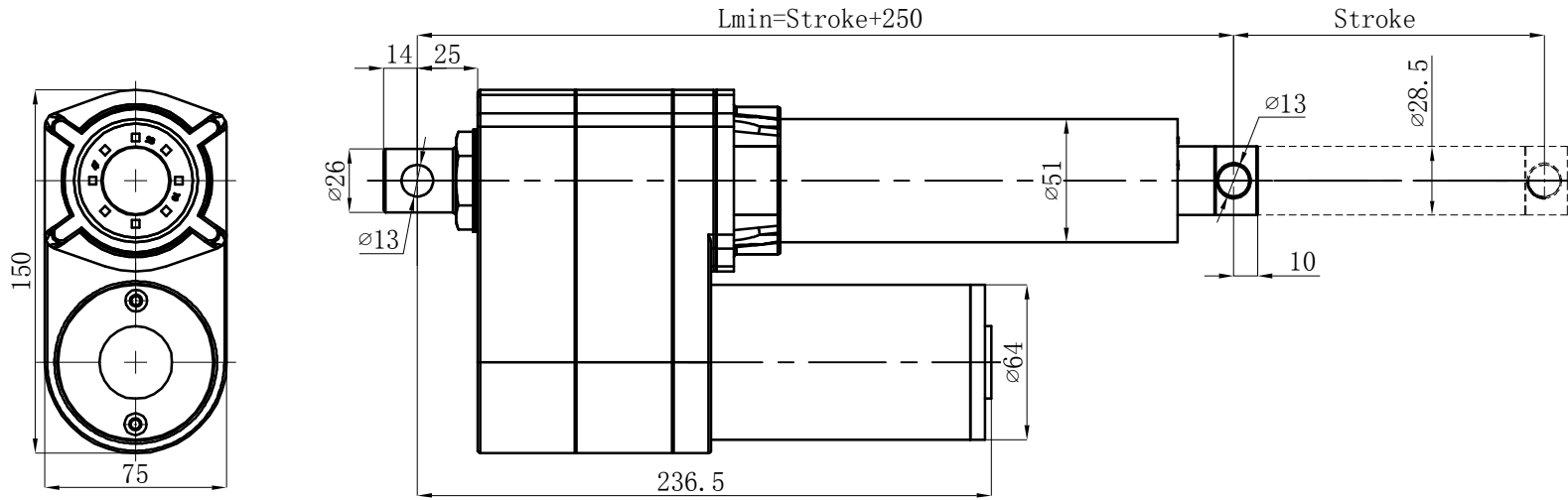

Built in Potentiometer or Hall (Optional)

Specifications

1	Input Voltage	48V/36V/24V/12V DC
2	Load Capacity	10000N
3	Max Speed	5 mm/s (7000N)
		67 mm/s (750N)
4	Stroke	Customize
5	Type of duty	10%, 2 min. on/18 min. off
6	Limit switches	Inner
7	Operation Temperature	-15°C~45°C
8	Color	Black or Gray
9	Protection Class	IP65

					Name	Installation Drawing		Figure Number	BM-H2	
					Materials			Drawing		
Sign	Amount	Modify File Number	Signature	Date						
Designer			Standard		Weight		Ratio	1:3	Lay	Page
Mapper					Wuxi Borman Transmission Technology Co., LTD					
Auditor										
Craft			Approver							