

Installation Dimension

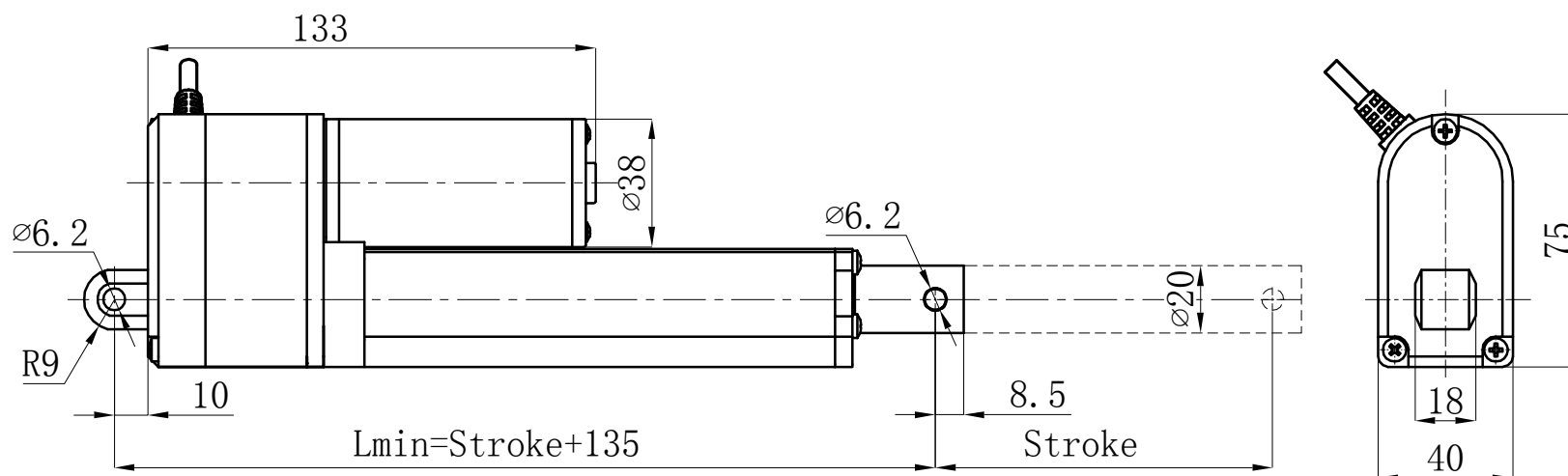

Specifications

1	Input Voltage	48V/36V/24V/12V DC
2	Load Capacity	1200N
3	Speed	5~120 mm/s
4	Stroke	Customize
5	Type of duty	10%, 2 min. on/18 min. off
6	Limit switches	Inner
7	Operation Temperature	-15°C~45°C
8	Protection Class	IP65

					Name	Installation Drawing		Figure Number	BM-S1	
					Materials			Drawing		
Sign	Amount	Modify File Number	Signature	Date	Weight	Ratio	1:3	Lay	Page	
Desinger			Standard							
Mapper										
Audtior										
Craft			Approver							
						Wuxi Borman Transmission Technology Co., LTD				