

Installation Dimension

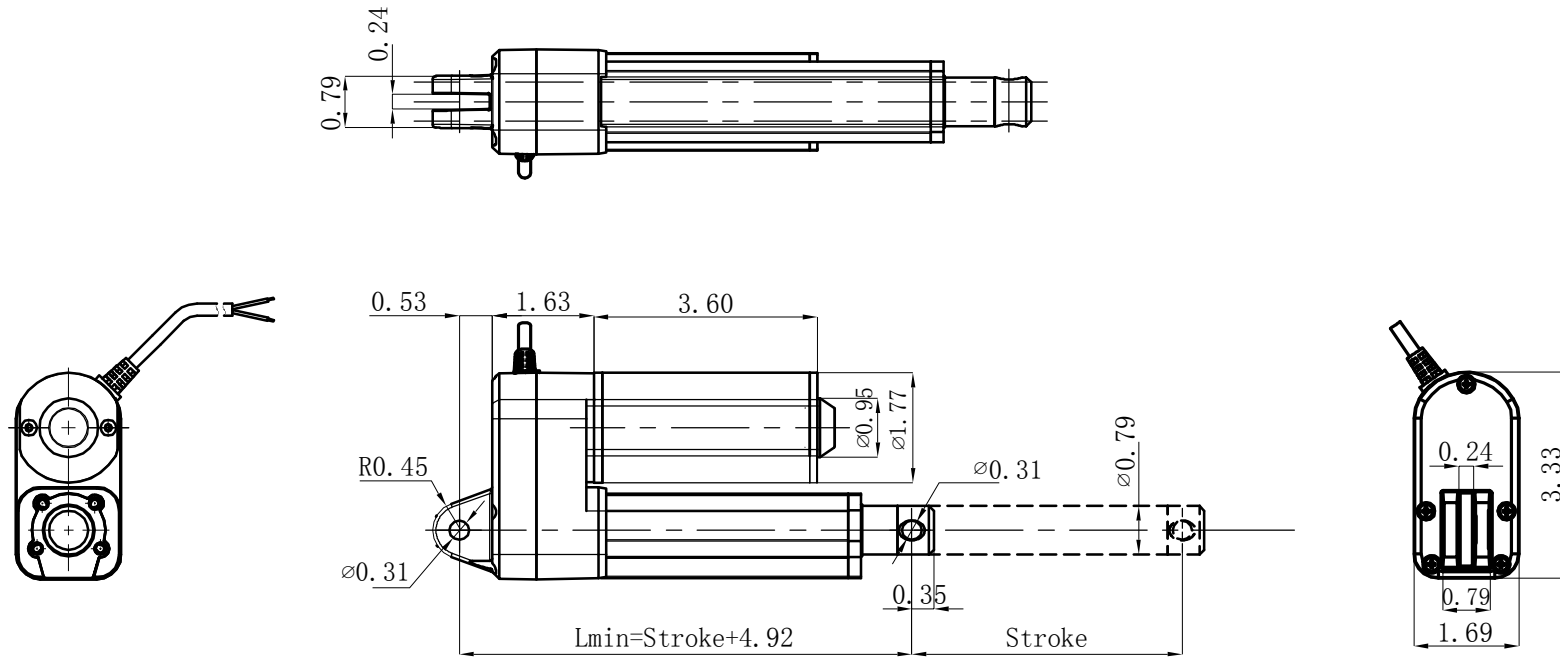

Specifications

1	Input Voltage	48V/36V/24V/12V DC
2	Load Capacity	2000N
3	Speed	7~20 mm/s
4	Stroke	Customize
5	Type of duty	10%, 2 min. on/18 min. off
6	Limit switches	Inner
7	Operation Temperature	-15°C~45°C
8	Protection Class	IP65

					Name	Installation Drawing		Figure Number	BM-S3	
					Materials			Drawing		
Sign	Amount	Modify	File Number	Signature		Date				
Designer				Standard		Weight	Ratio	1:3	Lay	Page
Mapper						Wuxi Borman Transmission Technology Co., LTD				
Auditor										
Craft				Approver						