

Installation Dimension

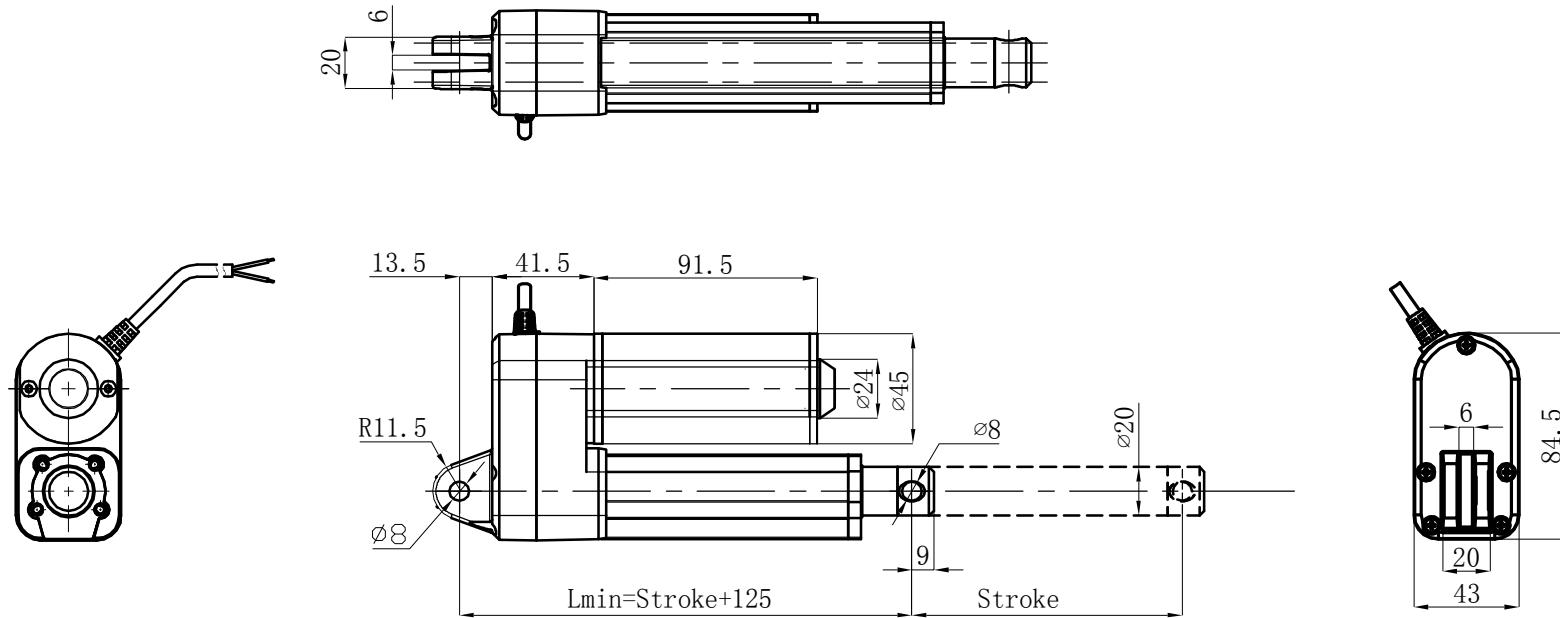

Specifications

1	Input Voltage	48V/36V/24V/12V DC
2	Load Capacity	2000N
3	Speed	7~20 mm/s
4	Stroke	Customize
5	Type of duty	10%, 2 min. on/18 min. off
6	Limit switches	Inner
7	Operation Temperature	-15°C~45°C
8	Protection Class	IP65

					Name	Installation Drawing		Figure Number	BM-S3
					Materials			Drawing	
Sign	Amonut	Modify File Number	Signature	Date	Weight	Ratio	1:3	Lay	Page
Designer			Standard						
Mapper									
Auditor									
Craft			Approer						



Wuxi Borman Transmission Technology Co., LTD