

Model: BM-10



• Product Description

BM-10 linear actuator is our fundamental linear actuator making it an ideal choice for many projects. This electric actuator is an optimal choice when a high force, low current actuator is required. Some examples of the key industries that use this cost-effective actuator solution include the automotive, home automation, and medical industries. For improved control and accuracy of motion, the BM-10 can be customized depending on your application requirements.

• General Features

Input Voltage	24V/12V DC
Load Capacity	1349lbs
Speed	0.15~1.18inch/s
Stroke	Customize
Type of Duty	10%, 2min.on / 18min. off
Limit Switches	Inner
Operation Temperature	-15°C~45°C
Protection Class	IP43
Color	Black or Gray
Certificate	CE,ROHS,SAA,FCC

1

Installation Dimensions

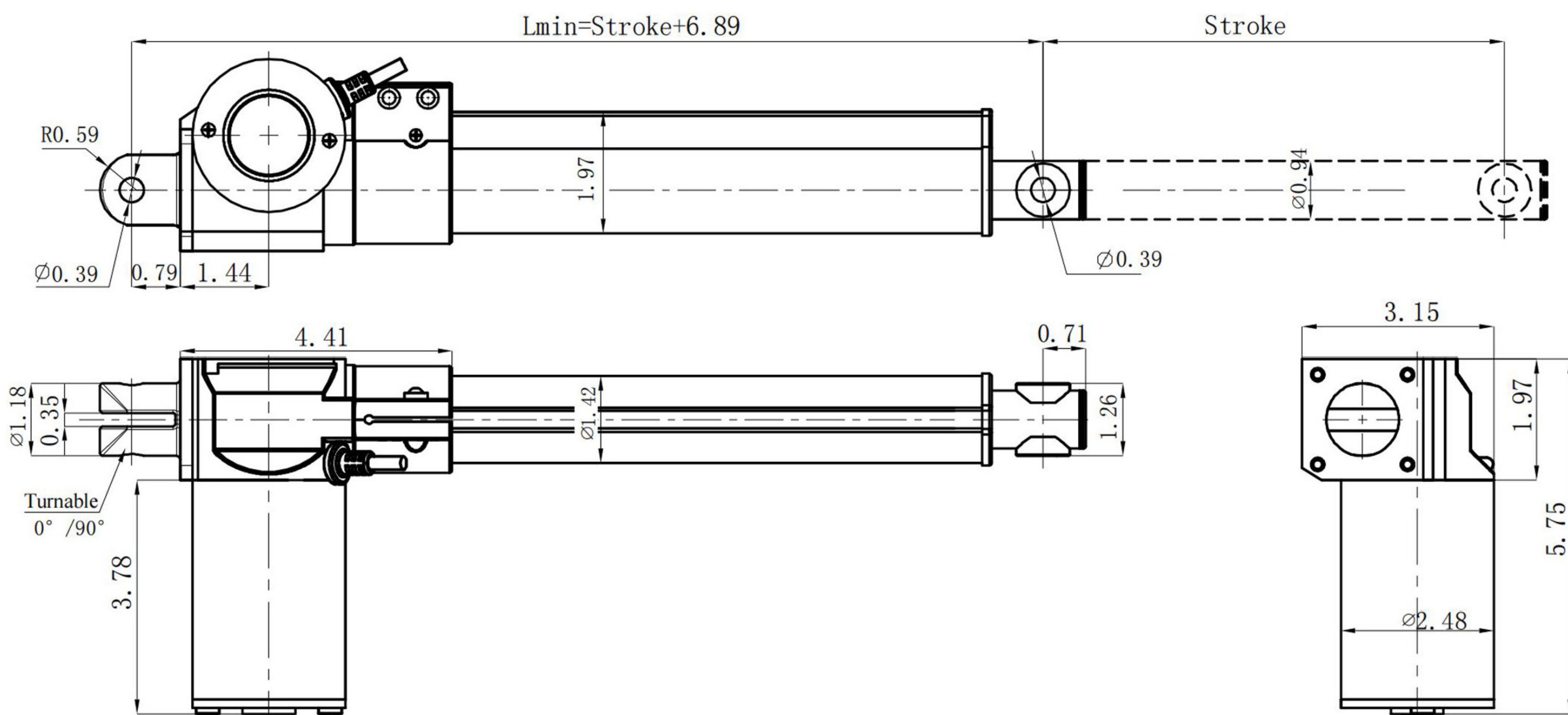

2

Load And Speed

CODE	Load (lbs)		Self Locking Force (lbs)	Typical Current (A)		Typical Speed (inch/s)	
	Push	Pull		No Load 12V/24V/48V DC	With Load 12V/24V/48V DC	No Load 12V/24V/48V DC	With Load 12V/24V/48V DC

Motor Speed						
A	1323	1323	1323		0.16	0.12
B	1102	1102	1102		0.24	0.16
C	882	882	882		0.31	0.24
D	441	441	441		0.47	0.35
E	176	176	176		0.63	0.55
F	110	110	110		0.94	0.71

3