

Model:BM-S2

Product Description



BM-S2 linear actuator meets specific application requirements of its clients. The BM-S2 is perfect for use in small spaces where force or capability cannot be sacrificed. It is compact, robust and capable of performing well in certain outdoor environments. The compact size helps reduce maintenance relates issues associated with many large linear actuators. The BM-S2 linear actuator is regularly employed in various commercial, as well as residential applications. The actuators are flexible, which mean they can meet requirements of any complex application. It helps create and maintain a high level of manufacturing quality, efficiency, and adds to the organization's overall profitability. For improved control and accuracy of motion, the BMS2 can be customized depending on your application requirements.

General Features

Input Voltage	48V/36V/24V/12V DC
Load Capacity	2500N
Speed	7-70mm/s
Stroke	Customize
Type of Duty	10%, 2min.on / 18min. off
Limit Switches	Inner
Operation Temperature	-15°C~45°C
Protection Class	IP65
Color	Black or Gray
Certificate	CE,ROHS

1

Installation Dimensions

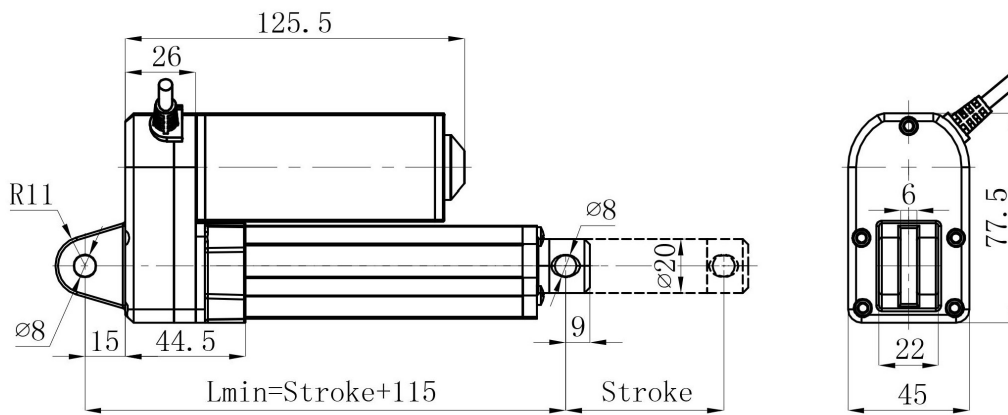

2

Load And Speed

CODE	Load (N)		Self Locking Force (N)	Typical Current (A)		Typical Speed (mm/s)	
	Push	Pull		No Load 12V/24V DC	With Load 12V/24V DC	No Load 12V/24V/48V DC	With Load 12V/24V/48V DC
<b>Motor Speed</b>							
A	2200	2200	2500	0.8-1/0.7-0.9		7	6
B	1800	1800	2000	0.8-1/0.6-0.9		9	8
C	1500	1500	1500	0.8-1/0.7-0.9		11	9
D	1400	1400	1500	0.8-1/0.7-0.9		14	12
E	900	900	1000	0.8-1/0.7-1		19	16
F	800	800	1000	0.8-1.2/0.7-0.9		17	16
G	500	500	750	0.8-1.2/0.7-1.1		27	25
H	350	350	500	0.8-1.4/0.7-1.1		35	31
I	150	150	300	0.8-1.5/0.7-1.1		56	54

3